



EQ-FE20

# Whole House Water Filter **Iron Filter**

Owner's Manual





Meet clean, healthy water. Your new Aquasana Whole House Iron Filter was expertly engineered to reduce iron commonly found in well and city water.

Enjoy the peace of mind that comes from knowing our award-winning water filter technology is working for you.

---

EQ-FE20

# Whole House Water Filter Iron Filter

## TABLE OF CONTENTS

|                              |       |
|------------------------------|-------|
| Box Contents .....           | 1     |
| System Configuration .....   | 2-3   |
| Use & Care .....             | 4     |
| Installation Steps.....      | 5-9   |
| Troubleshooting Guide .....  | 9     |
| Performance Data Sheet.....  | 10    |
| Warranty .....               | 11-12 |
| Water for Life® Program..... | 13    |

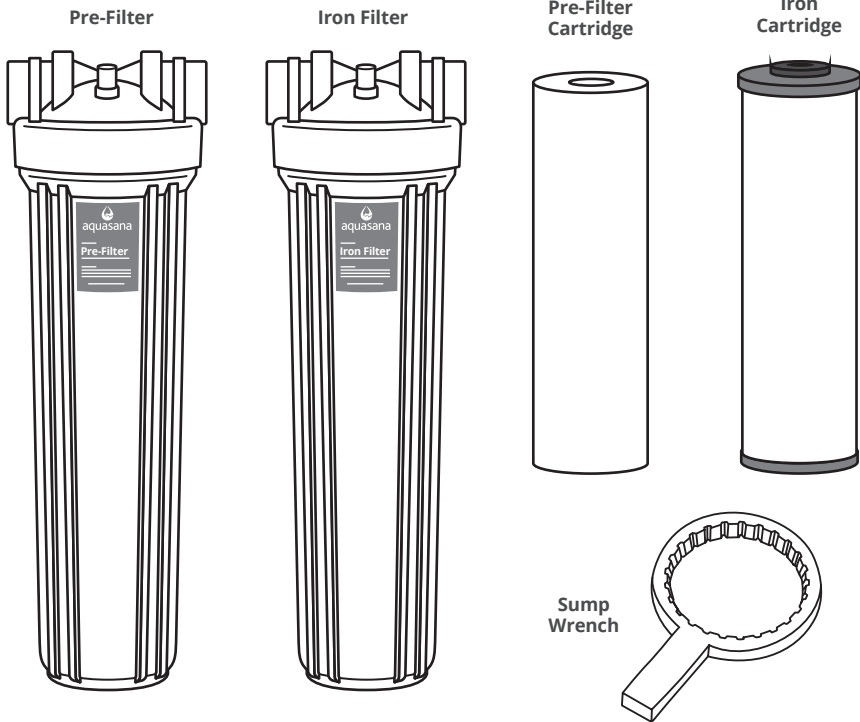

Support Bracket (2)

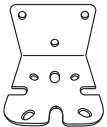

Shut-Off Valve

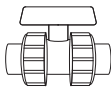

Threaded Valve Adapters (2)



Reducer Bushing



Slip Unions (2)



3" Nipples (5)



Parts and pieces included with your system will vary depending on your specific order. Please call Customer Service with any questions or concerns **866-662-6885**.

**Tools recommended for installation:**

- NSF certified plumber's tape
- Adjustable wrench
- Pipe cutter
- Allen wrench 5mm
- NSF approved PVC primer and glue
- Copper wire & grounding clamps (if copper pipes are present)

*Additional tools may be required depending on desired setup and location of system.*

## 2 SYSTEM CONFIGURATION

### Stand-Alone Iron Filter System

Note the correct sequencing below.

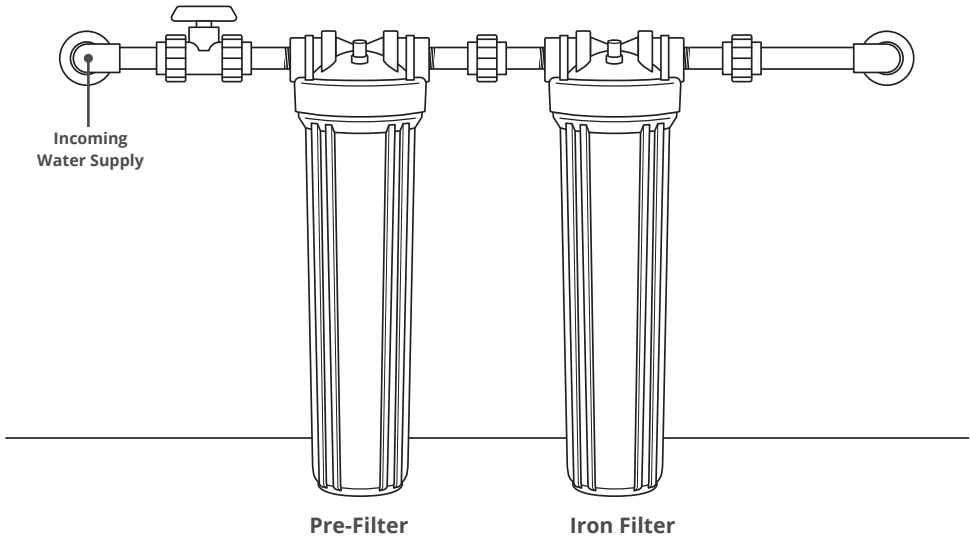

### Complete Water Filtration System

Installation shown below includes a bypass loop.

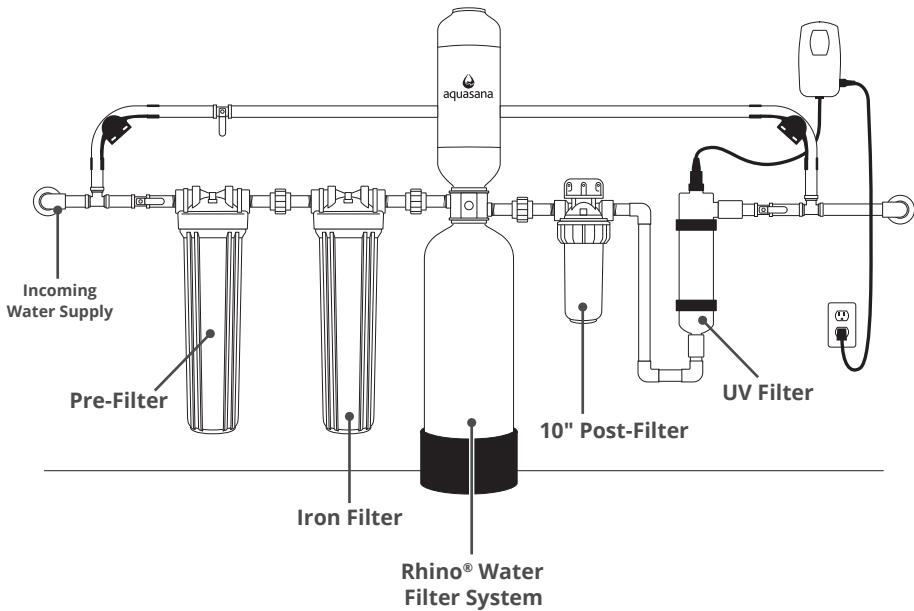

## Before installing

- **Lay out system in appropriate configuration. Improper sequence of equipment will affect performance and could possibly damage your system.**
- Pick an appropriate installation location. Dimensions of systems vary.
  - **Iron Filter System with Well Water Rhino:**  
54" x 57" (LxH)
  - **Iron Filter System with Salt-Free Conditioner + Well Water Rhino:**  
66" x 57" (LxH)
- Install housings at appropriate height for easy filter changes.
  - **Iron Filter System:** 30" high
  - **Iron Filter System + Rhino Water Filter:** 37.5" high
    - If attaching to a Rhino Well Water system, it should be installed at a minimum height of 37.5" to align inlets.
- **For all installations:** Anticipate the need for additional parts and pieces including but not limited to pex tubing, clamps, and mounting screws to install unit properly (available at a local home improvement stores or through your plumbing contractor). Due to the varieties of home design, not all configurations can be addressed in this guide.
- **DO NOT** install this filter where the line pressure may exceed 100 psi. The operating pressure range for this filter is between 20psi – 100psi.
- Install on cold water lines only 40°– 90°F (4.4° – 32.2°C).
- Installation of the filtration system must comply with existing state and local plumbing codes. Aquasana and its manufacturer are not liable for consequential or incidental damages due to improper installation.
- **DO NOT** install the unit on its side. It must be installed upright to maximize contact with media bed.

**Read all precautions and installation instructions carefully and completely before installing.**

### Precautions

- Properly tighten all fittings to ensure a leak-free assembly.
- NSF certified plumber's tape (thread sealing tape) is the only sealer that can be used on threaded fittings. **DO NOT** use pipe dope or PVC primer/glue on threaded fittings. Exposure to these compounds will damage nipples causing leaks.
- **DO NOT** sweat fittings near filter housings or any plastic parts.
- Piping and filter housings must be properly supported with pipe hangers.
- Unit must be installed in an area where the main water line enters your home, before connecting to the water heater. **DO NOT** install after a water heater or on the hot water line.
- It is recommended your system be installed indoors and out of direct sunlight. Prolonged exposure to light can weaken plastic components, resulting in filter housing failure. If this is not possible and the system is outdoors or in a sunny area, the unit must be protected from both direct sunlight and freezing temperatures.
- If installing on metallic plumbing, two grounding clamps and #4 copper wire are essential for safety.

- Some local codes may require the use of a licensed plumber or certified installer when disrupting a potable water line.
- In areas with high pressure, a pressure relief valve and a water hammer arrestor may be necessary.

### Cleaning

The exterior of your filtration system can be cleaned with warm, soapy water. Rinse well with fresh, clean water.

**NOTE:** Never use chemical cleaning products on the system's exterior surface as they may damage the housing.

### Replacements

This filter system is designed and tested for use with genuine Aquasana parts including replacement filters and all hardware. Use of parts from other manufacturers may result in loss of contaminant reduction performance, system damage, or failure. Use of parts from other manufacturers will also void your warranty. Please visit [aquasana.com](http://aquasana.com) for replacement installation and parts.

A Pre-Filter and Iron Filter are included with your system. Sediment levels vary from one location to another. It is recommended to replace your filters every 6 months. If the flow rate has noticeably decreased, replace your filters sooner.

#### **Model: EQ-FE20**

Iron Filter Replacement: EQ-FE20-R

#### **Additional Replacements:**

20" Pre-Filter: EQ-PRE-204-R

1 Select Location

**⚠ WARNING**

Before installing, lay out system in appropriate configuration. Improper sequence of equipment will affect performance and could possibly damage your system. **DO NOT** install after the water heater or on the hot water line. Components and installation will vary.

Turn off the main water source prior to installation. Drain water from lines to relieve pressure by turning on a faucet inside your home.

2 Filter Sequencing

1. Pre-Filter must be installed first followed by the Iron Filter and any additional add-ons (Salt-Free Conditioner, Rhino tank, Post-Filter, UV Filter, etc.). Measure distance for all components and mark pipe accordingly.
2. Unscrew and remove tops of the Pre-Filter and Iron Filter housings.
3. Remove filter cartridges from filter housings and inspect to ensure that the filters have not been damaged and there is no plastic or other objects stuck to the filters.

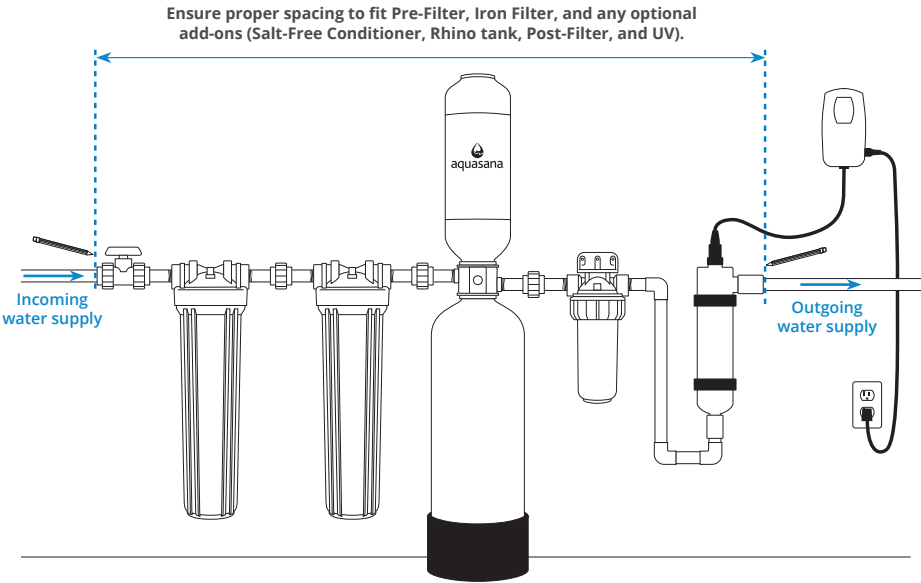
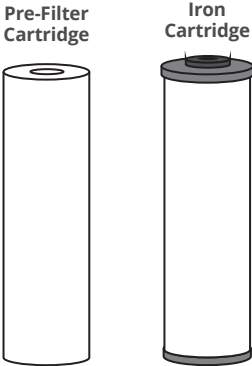

## 6 INSTALLATION STEPS

### ③ Filtration System Add-Ons Preparation

If you've added any additional components to your filtration system, stop now and read the separate, individual manuals for those systems in their entirety.

### ④ **COPPER PIPES ONLY** (proceed to Step 5 for PVC Pipes)

When installing on metallic plumbing, ensure you take the following precautions. Securely install two (2) grounding clamps and a #4 copper wire (not included) across the location where the system will be installed. Tightly clamp at both ends, as shown in the illustration.

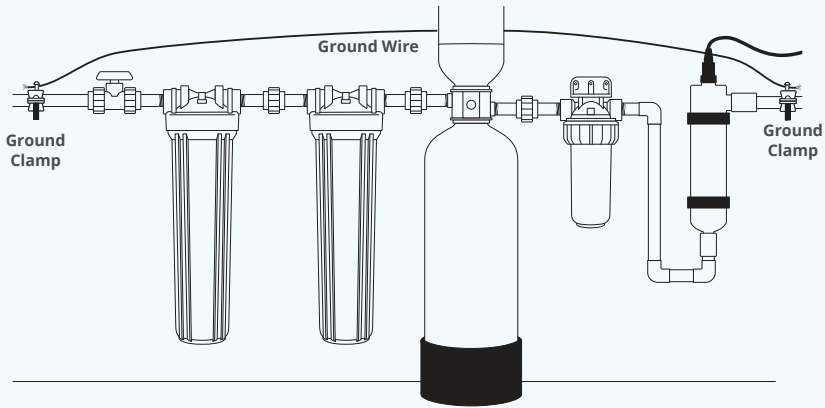

#### **⚠ WARNING**



#### **ELECTRICAL SHOCK HAZARD**

Prior to installation on metallic plumbing, securely install two grounding clamps and a #4 copper wire per installation instructions. Failure to follow these instructions can result in death or electric shock.

### ⑤ Cut Pipes

1. Using a pipe cutter, cut into the main water supply line along the marked sections from step 2 to install the shut-off valve and clean ends of pipe. Ensure there are no burrs, sharp edges, or deep scratches. Cut tubing as straight as possible with a utility knife, or an appropriate pipe cutter for copper tubing or PVC.
2. If you are installing a bypass loop, now is the time to plan accordingly and install (recommended, not included).
3. Loosely fit shut-off valve to calculate proper spacing of components.

**NOTE: DO NOT** cut more pipe than necessary. You can cut more pipe later if needed.

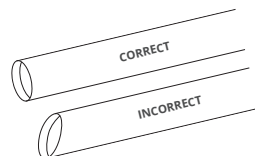



6 **Configure System**

1. Fit Pre-Filter and Iron Filter into the desired location.

**NOTE:** The caps are marked with "IN" and "OUT" on the top of the housing.

2. Using the provided screws, mount the brackets to the sump caps in accordance with desired flow direction. Hand tighten, and then use an Allen wrench to complete tightening.

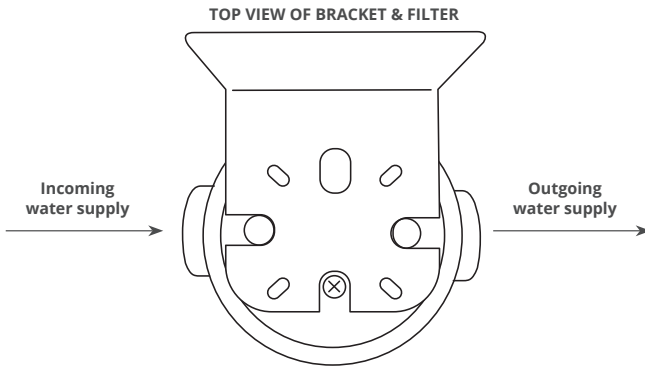

**NOTE:** If you need to position the flow direction to the right or left, the bracket will need to be turned 180 degrees.

3. Mount the brackets and caps to the wall using appropriate fasteners for your wall material. Screws used to mount brackets to the wall are not provided.

**NOTE:** Ensure wall material is stable enough for mounting purposes. The filter housing will become very heavy when full of water.

7 Connect System

**⚠ WARNING**

Properly connect system together accordingly (slip fittings, barbed fittings, NSF certified PVC glue, etc.). All parts must flow through the "IN" port in the correct direction of water flow.

1. Review the diagram below for proper order of parts. If incoming water supply line is 1", now is the time to use the supplied reducer bushing and threaded valve adaptor to reduce to ¾".

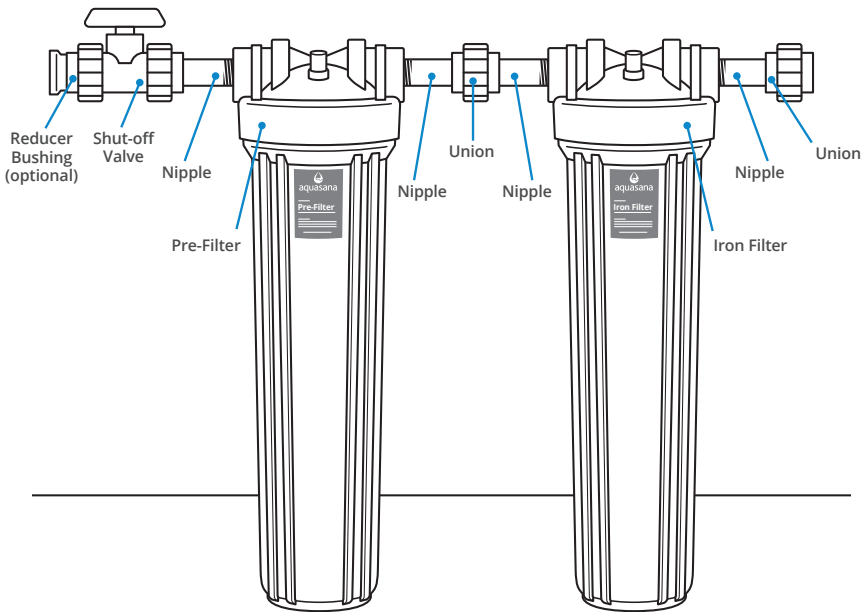

2. Wrap the pipe nipples with NSF certified plumber's tape clockwise (2-4 wraps).
3. Connect parts together according to diagram using proper materials per manufacturer instructions (glue, threaded fittings, etc.).
4. If you are installing a Complete Filtration System, connect the additional parts and filters now. Use the owner's manuals provided with those products for installation instructions.

**NOTE:** If only installing the Stand-Alone System, there will be an extra 3" nipple.

**8 Insert Filters**

1. Insert the Pre-Filter into the first housing labeled "Pre-Filter". Insert the Iron Filter into the housing labeled "Iron-Filter".

**NOTE:** The notch in the bottom of the housing centers the filter cartridges.

2. Coat the O-rings of both filter housings with the included lubricant.
3. Manually tighten the housings to the sump caps, and then use the provided sump wrench to tighten the housings.

**NOTE:** You should only need to use the wrench for a 1/8 to a 1/4 of a turn with the wrench.

**9 Final System Check**

Once installation is complete, allow proper time for glue to dry according to manufacturer instructions. Then, slowly turn on main water supply. Once system has fully pressurized, inspect for leaks.

After inspecting for leaks, turn on the faucet closest to the installed unit and allow water to run for 2 minutes for the final flushing period.

| Troubleshooting Guide                        |   |   |
|--|---|---|
| Malfunction                                  | Cause   | Remedy  |
| Leaks between housing sump and housing head. | a. Housing not sufficiently tightened.<br>b. O-ring affected/old.                                   | a. Tighten the housing further with the wrench.<br>b. If the housing still leaks, change the housing's O-ring with a new one.                     |
| Leaks in inlet/outlet connections.           | a. Not enough sealant and/or connection not sufficiently tightened.<br>b. Improper connection type. | a. Remove the previously applied plumbers tape and re-apply plumbers' tape. Tighten the connection properly.<br>b. Only use NPT tapered fittings. |



| Performance Data for the Whole House Iron Filter — EQ-FE20                                 |                              |                 |                          |                       |
|--|------------------------------|-----------------|--------------------------|-----------------------|
| Model  | Replacement                  | Rated flow      | Max Operating pressure   | Operating temp. range |
| EQ-FE20  | EQ-FE20-R                    | 7.0 gpm         | 100 psi                  | 40-90° F              |
| Size   | Iron Reduction Filter Rating | pH Requirements | Pre-Filter Micron Rating |                       |
| 20"x4.5"   | Up to 3ppm iron reduction    | >7 pH           | 5 micron                 |                       |
| Manufactured by: AquaSana, Inc. 6310 Midway Road · Haltom City, Texas 76117 · 866-662-6885 |                              |                 |                          |                       |

Internally Tested Performance Data for the Whole House Iron Filter: No harmful chemicals are added to the water making it completely safe for drinking water applications.

| Approximate Life of System     |                  |                          |                    |                    |                   |
|--------------------------------|------------------|--------------------------|--------------------|--------------------|-------------------|
| Iron Reduction Filter Capacity | Water Iron Level | Total Gallons Water Used | 250 GPD (4 people) | 125 GPD (2 people) | 75 GPD (1 person) |
|                                | 3 ppm            | 26,000 gal               | 104 days           | 208 days           | 416 days          |
|                                | 2 ppm            | 40,000 gal               | 160 days           | 320 days           | 640 days          |
|                                | 1 ppm            | 80,000 gal               | 320 days           | 640 days           | 1280 days         |
|                                | .5 ppm           | 160,000 gal              | 640 days           | 1280 days          | N/A               |



**Do not use with water that is microbiologically unsafe or of unknown water quality without adequate disinfection before or after the system.**

- All contaminants reduced by this filter are listed.
- Not all contaminants listed may be present in your water.
- Does not remove all contaminants that may be present in tap water.



Filter is only to be used with cold water.



Filter usage must comply with all state and local laws.



Testing was performed under standard laboratory conditions, actual performance may vary.



Systems certified for cyst reduction may be used on disinfected waters that may contain filterable cysts.



See owner's manual for general installation conditions and needs plus manufacturer's limited warranty.

## IRON FILTER LIMITED WARRANTY

### Who is covered

AQUASANA AND ITS SUPPLIERS, (herein collectively referred to as "Manufacturer") warrants to the owner of the home where the water filter is initially installed (hereinafter "Owner"). The warranty is restricted to the water filter used in a single-family residence in the United States of America and is void if moved from the original installation location.

### What is covered

This Warranty covers defects in materials or workmanship during the limited warranty period of your Aquasana Iron Filter including sub-components purchased with original system (may or may not include Pre-Filter, and fittings), except as provided below. The water filter is warranted only when it is installed, operated, and maintained in accordance with the instructions accompanying the water filter found on Aquasana.com. A water filter should be installed in such a manner that, if the tank or any connection thereto should leak, the resulting flow of water will not cause damage to the area in which it is installed. For detailed instructions, read the manual accompanying the water filter and review drawings in the manual.

### For how long

This warranty runs for months specified in chart below from the date of purchase by a consumer (hereinafter "Warranty Period"). No warranty coverage will be provided if the claimant is unable to provide proof of purchase. Water conditions and use rates may limit the functional life span of your filter. This Limited Warranty does not extend to the full estimated life span of the filter.

### What Aquasana will do

1. If necessary, the Manufacturer will provide a replacement that fulfills the remaining estimated life span/capacity (see chart) of your original purchase and send it to you with installation instructions. If industry standards, product improvements, or product obsolescence prohibit Manufacturer from furnishing an identical model replacement water filter under this warranty, the Owner will be furnished with a new water filter of comparable remaining capacity and functionality; however, the Owner will be charged for the additional value of the item(s) which Manufacturer has incorporated in the replacement water filter.

| RHINO SYSTEM WARRANTY COVERAGE   |                    |
|--|--------------------|
| Model  | Life Span/Capacity |
| EQ-FE20  | 1 Year             |
| Installation Kit<br><i>(includes Pre-Filter and fittings purchased with original system)</i> | 1 Year             |

2. Component Part – If any component part proves to Manufacturer's satisfaction to be defective in material or workmanship within the warranty period listed on the data plate label, the Manufacturer will furnish the Owner with a replacement for the defective part(s).
3. Return of Defective Water Filter and Component Parts – Manufacturer reserves the right to examine the alleged defect in the water filter or component part(s), and it will be the Owner's obligation to return the water filter and/or component part(s) to the Manufacturer at the Manufacturer's request.
  - a. When returning a water filter, it must include all component parts.
  - b. When returning component part(s), they must be individually tagged and identified with the water filter's model number, date of purchase, and date of installation.

## What is not covered

1. This warranty does not cover filter cartridges and any systems that were not installed in compliance with the instructions or that have been abused or operated incorrectly.
2. The Limited Warranty stated herein is in lieu of any and all warranties, express or implied (whether written or oral), including, but not limited to, the implied warranties of merchantability and fitness for a particular purpose.
3. Manufacturer shall not be liable for any incidental, consequential, special, or contingent damages or expenses, arising, directly or indirectly, from any defect in the water filter or the use of the water filter.
4. Manufacturer shall not be liable for any water damage arising, directly or indirectly, from any defect in the water filter or component part(s) or from its use.
5. Manufacturer shall not be liable for any damage or product failures caused by any of the following:
  - The water filter or any of its component parts have been subject to misuse, alteration, neglect or accident.
  - The water filter has not been installed in accordance with the applicable local plumbing and/or building code(s) and/or regulations or in their absence.
  - The water filter is not installed, operated, and maintained in accordance with the printed Manufacturer's instructions, including if the water filter has any additional aftermarket equipment introduced into the sealed system not approved by the manufacturer.
  - The water filter is exposed to highly corrosive conditions.
  - The water filter is not continuously supplied with potable water.
  - The water filter is not operated within the factory calibrated temperature limits.
  - The water filter is removed from its original installation location.
  - The water filter is installed in direct sunlight or exposed to freezing temperatures.
  - The water filter or any of its component parts fail due to sediment build-up.
  - Clogging due to purchaser's failure to replace the Pre-Filter cartridge.
  - Damage caused by fire, flood, or acts of God.
  - Damage caused by over-pressurization in the water line.
6. This warranty does not cover damage caused by the use of parts that are not genuine Aquasana parts. This includes, but is not limited to replacement filters, faucets, and/or diverter valves.
7. Except when specifically prohibited by the applicable state law, the Owner, and not the Manufacturer, shall be liable for and shall pay for all charges for labor or other expenses incurred in the removal, repair, or replacement of the water filter or any component part(s) claimed to be defective or any expense incurred to remedy any defect in the product. Such charges may include, but are not necessarily limited to:
  - a. All freight, shipping, handling, and delivery costs of forwarding a new water filter or replacement part(s) to the owner.
  - b. All costs necessary or incidental in removing the water filter or component part(s) and installing a new water filter or component part(s).
  - c. Any material required to complete, and/or permits required for, installation of a new water filter, or replacement part(s), and
  - d. All costs necessary or incidental in returning the water filter or component part(s) to a location designated by the manufacturer.

## How to get service

To receive service under this Warranty, you must contact Aquasana (A. O. Smith Water Treatment (North America), Inc.) at 1-866-662-6885 or [warranty@aquasana.com](mailto:warranty@aquasana.com) within the Warranty Period to describe the problem to a customer service representative who will verify that the product is under warranty and determine whether a part or the system will be replaced and whether you must send back the unit. You will be required to provide proof of purchase and proof of proper installation.



# water for life®

## Replace your filters on time, without worry — auto-delivered to you, for less.

It's important to change your filters using genuine Aquasana replacements for continued water filtration and optimum system performance. This is why we offer our no contract, auto-ship filter replacement program called Water for Life®.



### Free Shipping

Replacements shipped directly to you, right when you need them, at no extra cost.



### Discount Replacements

Lock in a 15% discount on filters to ensure you always get the best price.



### Extended Warranty

Our performance promise to you – free replacement parts, just in case.



### No Contract

Replacing your filters is serious – but your commitment doesn't have to be.

## CONTACT US TO LEARN MORE



866-662-6885



[waterforlife@aquasana.com](mailto:waterforlife@aquasana.com)



### LOVE IT?

Please let us know with a review on Aquasana or your retailer's site.



### NEED HELP?

Give us a call at **866-662-6885** and tell us what's going on.

**Aquasana, Inc.**  
6310 Midway Road  
Haltom City, Texas 76117  
866.662.6885 USA  
877.332.7873 Canada  
[www.aquasana.com](http://www.aquasana.com)